

Summer Scottish Country Dancers - Edinburgh - 10 June 2025

Fairmilehead Church Hall, Frogston Avenue

1 CATCH THE WIND R32 · 3/4L

Romaine Butterfield: RSCDS XLV 5 · Crib: MiniCrib · Diagram: Keith Rose's Diagrams

- 1-8 1s set, cast 1 place & dance 1/2 Fig of 8 round 2s
- 9-16 1s set twice with 1L pulling back RSh on bars 11-12 to face out, 1L followed by partner casts up & dances down the middle 1L to face 3M **while** 1M faces 2M
- 17-24 1s RSh reels of 3 across (1M with 2s & 1L with 3s)
- 25-32 1L followed by partner dances down cast up round 3M & crosses to end in 2nd place on own sides, 1s turn RH (4 bars)

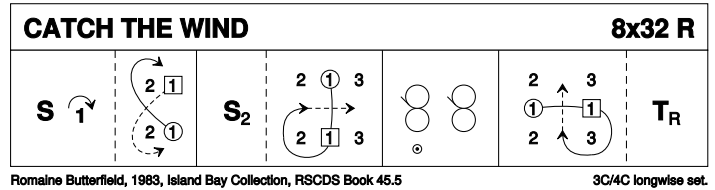

2 EH3 7AF J32 · 3/4L

Roy Goldring: RSCDS XL 6 · Crib: MiniCrib · Diagram: Keith Rose's Diagrams

- 1-8 1s lead down the middle & back to top. 2s & 3s step in on bar 8 ready for ...
- 9-16 1s+2s+3s Promenade ending with 1s casting to 2nd place
- 17-24 1s pass by the right & turn 1st corners RH to end L between 2s & M between 3s, 1s pass by the right & turn 2nd corners RH to end between crnrs
- 25-32 1M dances RH across with 2s & 1L with 3s, 1L dances up between 2s & casts to 2nd place own side as 1M dances between 3s & casts up

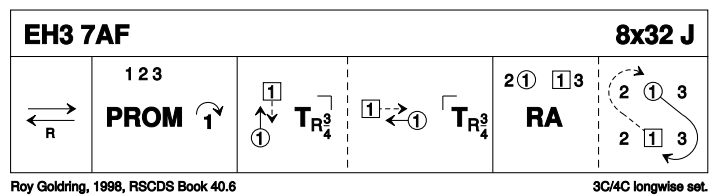

3 THE DREAM CATCHER S96 · 4S

Eileen Orr: RSCDS XLV 9 · Crib: MiniCrib · Diagram: Keith Rose's Diagrams

- 1-8 All circle 8H round & back
- 9-16 1s+3s dance the Swirl:
9-10 Turn partner RH into Allemande hold
11-12 Dance LSh round other couple 1/2 way, on bar 12 drop right hands
13-16 1s+3s dance LH across. On bar 16, pull back LSh & dance on to face side couples (BtoB with ptrn & Lady facing Man, 1L & 3M face 2s, 3L&1M face 4s)
- 17-24 All dance reels of 4 across
- 25-32 All set & dancing couples dance out between side couples, cross & cast to change places RH with partner back into places
- 33-40 All set & advance with partners, retire diagonally with corners & set
- 41-48 1L+4M dance R&L with 3L+2M (on diagonal)
- 49-56 1M+2L dance R&L with 3M+4L (other diagonal)
- 57-64 All set with corners, Adv+Ret with partners & set
- 65-88 2s & 4s repeat bars 9-32
- 89-96 All circle 8H round & back

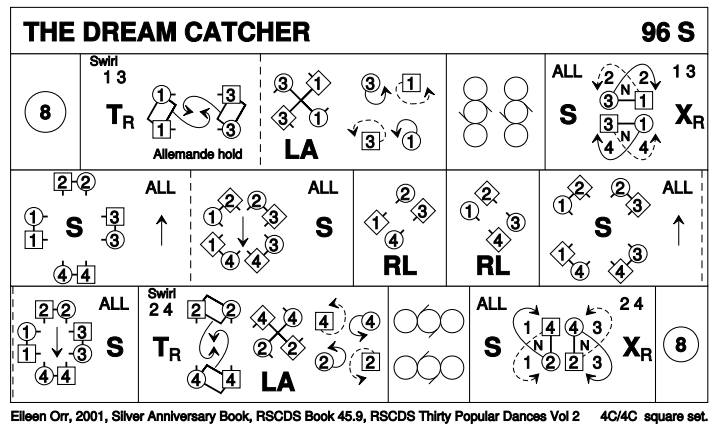

4 THE WESTMINSTER REEL R32 · 2/4L

Jeremy Hill: RSCDS XLV 1 · Crib: MiniCrib · Diagram: Keith Rose's Diagrams

- 1-8 1M+2L turn RH, 1L+2M turn RH 1.1/2 times end facing partner ready for diagonal reel of 4
- 9-16 1s+2s dance diagonal reel of 4. All end in original places
- 17-24 1s+2s Set & Rotate :
Set (facing diagonally opp dancer), rotate singly & dance on 1 place clockwise, change places RH on sides & dance on 1 place to own sides (1s in 2nd pl)
- 25-32 2s+1s dance R&L

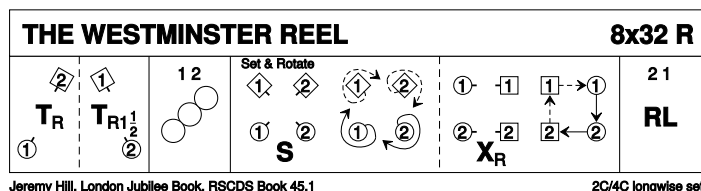

5 WELCOME TO AYR J32 · 3/4L

Jill Henriksen/Kathy Stewart: RSCDS XLVII 8 · Crib: MiniCrib · Diagram: Keith Rose's Diagrams

- 1-8 1s+2s dance double Fig of 8 (1s cross down to start)
- 9-16 1s turn 2s on sides (Men RH, Ladies LH) & 1s dance down to turn 3s on sides (Men RH, Ladies LH) & 1s end facing 1st corners
- 17-24 1s dance 1/2 reel of 4 with corners & pass RSh to face 2nd corner, 1s dance 1/2 reel of 4 with crnrs & 1s end in middle LSh to LSh facing own sides
- 25-32 1M+3s (at top) also 1L+2s dance RH across (1s end in 2nd place opposite sides), all chase clockwise 1/2 way to own sides

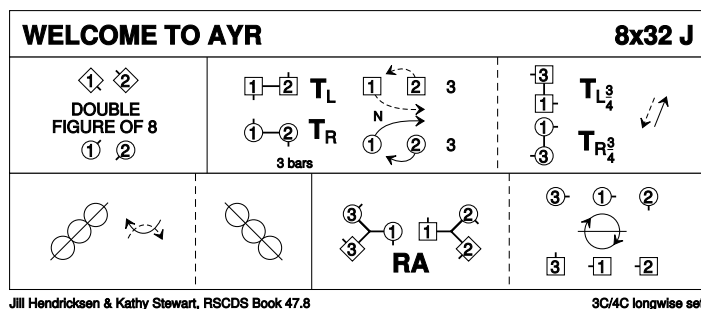

6 KILKENNY CASTLE S32 · 3/4L

Bill Forbes: Craigievar Book 2 · Crib: MiniCrib · Diagram: Keith Rose's Diagrams

- 1-8 1s+2s set, 1s cross RH & cast 1 place (2s step up), 1s dance in to meet partner & face down, 1s turn 3s with nearer hand to face up
- 9-16 1s dance reflection reels of 3 on sides (1s dancing in & up between 2s to start)
- 17-24 1s Petronella turn to middle as 2L+3L & 2M+3M change pl RH, set in lines across, 1s petronella turn to sides as 2s+3s cross RH & set on sides
- 25-32 1s dance Diag R&L (1M crossing down & 1L crossing up)

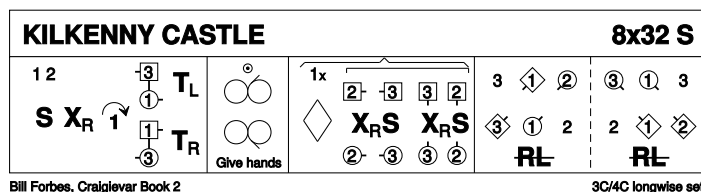

7 THE KELLOHOLM JIG J32 · 3/4L

Peter Hyssett: The Leaflet Dances with Music · Crib: MiniCrib · Diagram: Keith Rose's Diagrams

- 1-8 1s set & cast 1 place, set on side lines to 1st corners & change places with them RH
- 9-16 1L+3L also 2M+1M set to each other on sides & change places LH, 1s turn RH 1.1/2 times to 2nd place on own sides
- 17-24 1s set on side lines to 2nd corners & change places with them RH, 1M+3M also 2L+1L set to each other on sides & change places LH
- 25-32 3s+1s+2s Adv+Ret, circle 6H round 1/2 way to left

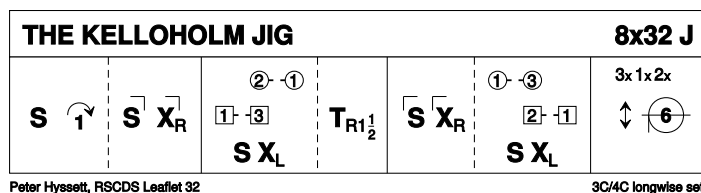

8 THE WATER OF LEITH S32 · 4/4L

John Wilkinson: RSCDS LIII 2 · Crib: MiniCribbs · Diagram: Keith Rose's Diagrams

- 1-8** 1s+3s set. 1L dances down, casts up round 2M into middle facing down as 1M dances across, casts round 2L into middle facing up **while** 3s dance same round 4s. 1s+3s change places RH with partner into line of 4 in middle (M face down, L face up)
- 9-16** 1s+3s dance reel of 4 in middle
- 17-20** 1s+2s also 3s+4s dance RH across
- 21-24** 1M followed by 1L casts round 2L to 2nd place own sides as 3M followed by 3L casts round 4L to 4th place (2s+4s step up 23-24)
- 25-32** 1s+4s (middle couples) dance Espagnole
- 25-26** 1s+4s cross (Ladies lead across RH passing between Men) with Ladies changing places RH
- 27-28** 1s+4s cross back (Men lead across RH between Ladies) with Men changing places RH
- 29-32** 4s turn RH as 1s turn LH

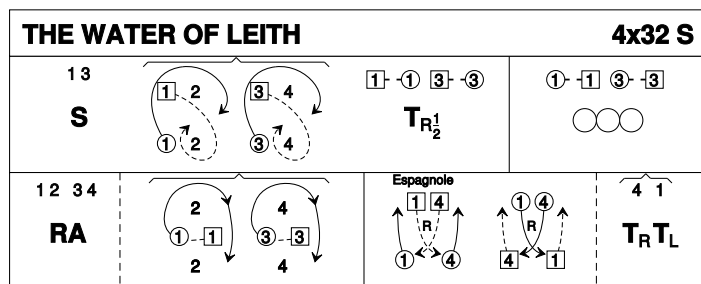

John Wilkinson, RSCDS Book 53, Edinburgh 90

4C/4C longwise set.

9 INVERNEILL HOUSE R32 · 3/4L

John Drewry: RSCDS XXXV 2 · Crib: MiniCribbs · Diagram: Keith Rose's Diagrams

- 1-8** 1s+2s dance 1/2 double Fig of 8 (1s cross down), 1s dance down between 3s as 2s dance out & up then 1s cast up to 2nd place opp sides
- 9-16** 1s+3s dance 1/2 double Fig of 8 (1s cross down), 1s dance up between 2s & cast to 2nd place own sides
- 17-24** 1s Petronella to opposite sides
- 25-32** 2s & 3s Petronella to own sides **while** 1s cast RSh round 1st corner & cross between 2s/3s, 1s cast to 2nd place own sides & all set

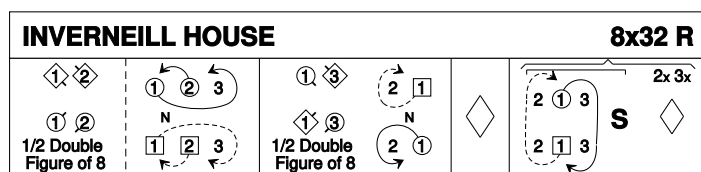

John Drewry, 1986, RSCDS Book 35.2

3C/4C longwise set.

10 THE HIGHLAND RAMBLER R40 · 3/4L

Roy Goldring: Thirty Popular Dances, Volume Two · Crib: MiniCribbs · Diagram: Keith Rose's Diagrams

- 1-8** 1s dance in & cast to 2nd place, dance RH across with 3s
- 9-16** 2s+1s dance LH across, 1L followed by partner cast up round 2L & dance down middle to 1L between 3s & 1M between 2s
- 17-24** 1s+2s+3s dance down the middle & back
- 25-32** 1M followed by partner dance up, cast down round 2L to 2nd places on own side & turn RH
- 33-40** 2s+1s+3s circle 6H round & back

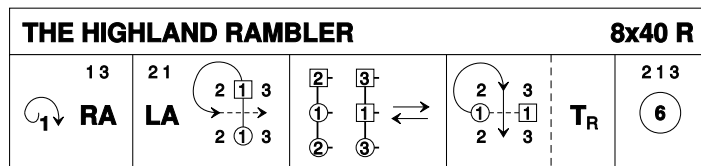

Roy Goldring, 1985, Leeds Silver Jubilee, RSCDS Thirty Popular Dances Vol 2

3C/4C longwise set.